



HAL
open science

RobAFIS student competition actuality: Safety & Security interactions between operators and with the system

Jean-Claude Tucoulou, David Gouyon

► **To cite this version:**

Jean-Claude Tucoulou, David Gouyon. RobAFIS student competition actuality: Safety & Security interactions between operators and with the system. INSIGHT - International Council on Systems Engineering (INCOSE), 2019, 22 (4), pp.11-13. 10.1002/inst.12266 . hal-02438786

HAL Id: hal-02438786

<https://hal.science/hal-02438786>

Submitted on 14 Jan 2020

HAL is a multi-disciplinary open access archive for the deposit and dissemination of scientific research documents, whether they are published or not. The documents may come from teaching and research institutions in France or abroad, or from public or private research centers.

L'archive ouverte pluridisciplinaire **HAL**, est destinée au dépôt et à la diffusion de documents scientifiques de niveau recherche, publiés ou non, émanant des établissements d'enseignement et de recherche français ou étrangers, des laboratoires publics ou privés.

RobAFIS student competition actuality: Safety & Security interactions between Operators and with the System

Jean-Claude Tucoulou (jeanclaude.tucoulou@incose.org) & David Gouyon (david.gouyon@incose.org)

This paper presents the RobAFIS competition which is yearly organized since 2006, by AFIS, the French chapter of INCOSE. This competition, as well as its pedagogical objectives, have been presented in previous editions on Insight [1] [2] [3] [4]. RobAFIS enhances AFIS action, offering educational and research institutions an operation to better understand and develop the use of systems engineering best practices, as recommended and formalized by AFIS. Two reference documents are recommended for RobAFIS :

- the book “To discover and understand Systems Engineering” [5].
- the book “Thinking System” [6].

Since 2007, Students and their supervising teachers have the opportunity to exchange with the jury AFIS expert members, working in industry or teaching Systems Engineering. During development, these experts answer, via a FAQ page on a RobAFIS dedicated collaborative space [7], questions about technical or methodological issues related to stakeholder requirements or to the development document.

The main objective of RobAFIS is to highlight the benefits of basing systems engineering education on a project life cycle realization: a full life cycle including the implementation of an operational system, deployed by a client, in a real environment.

1. A development in two phases

To enhance the distinction between system architectural choices and technology choices, since 2015 we proposed a model of development in two phases:

- Phase 1: an upstream study phase, with the supply of a preliminary development document (§2), focusing on the identification of possible solutions (at least 3 candidate solutions) and on the justified choice of the selected solution, on the basis of studied solutions drafts;
- Phase 2: a full development phase, with the supply of a detailed development document (§3) and an operational prototype, corresponding to the solution selected in the first phase.

The aim is to highlight the specific nature and contribution of both phases, in terms of progressive definition, the first one corresponding mainly to a system vision, the second one to a more product-oriented vision.

2. Preliminary development document architecture [8]

At the end of phase 1, student teams have to supply a preliminary development document, structured into 3 deliverables (more details on www.robafis.fr):

1. Preliminary version of requirement referential (Deliverable 10)
2. Presentation of possible architectural designs (Deliverable 20)
3. Justification of architecture choice (Deliverable 40)

3. Development Document Architecture [8]

The results of the full development phase 2 are supplied under the form of a detailed development document, structured into 8 deliverables (more details on www.robafis.fr):

1. Final requirement referential (Deliverable 10)
2. Final architectural design (Deliverable 20)
3. Reference configuration (Deliverable 30)
4. Justification of definition (Deliverable 40)
5. Integration, Verification, Validation Plan (Deliverable 50)
6. Maintainability study and maintenance definition (Deliverable 60)
7. Project management (Deliverable 70)
8. Assembly and verification instructions (Deliverable 80)

4. Recent technical subjects

Last years have seen various evolutions in the technical aspects of the case studies:

- 2015-2016-2017-2018: Interactions between operators and technical systems;
- 2017: Evolution of the two systems deployed simultaneously in a common environment;
- 2018: Evolution of the system in an environment imposing very high operational safety constraints and introduction of environmental requirements with a low ecological footprint and recyclability.

5. 2018: “13th edition” organized as part of the 20th anniversary of AFIS

This year, record participation was broken with 14 teams taking part in the competition (Figure 1) and around 100 teachers and students present for the final on 4 and 5 December 2018, an event hosted in Nancy by the University of Lorraine, at the Faculty of Science and Technology.

Equipes RobAFIS 2018	
IMT - Mines d'Alès	
Institut National des Sciences Appliquées Toulouse - INSATOMIQUE	
Institut National des Sciences Appliquées Toulouse - RED PANDA	
Ecole Internationale des Sciences du traitement de l'Information	
ITESCIA (CNAM)	
Université de Reims Champagne Ardenne – Master EEAI	
Université Technologique de Troyes – Département EAA	
Université de Bordeaux – Master GILOG	
Université de Lorraine - Master ISC	
Sigma-Clermont	
Ecole Nationale de l'Aviation Civile – SITA option ISI	
Université de Bourgogne Franche-Comté - Master on Green Mechatronics	
Université de Technologie de Compiègne - Master ISC	
UTC ESIEE – Master ISC	

Figure 1: Teams

The proposed subject concerned a robot for handling and transporting radioactive packages in the environment of a nuclear waste reprocessing center (Figure 2).

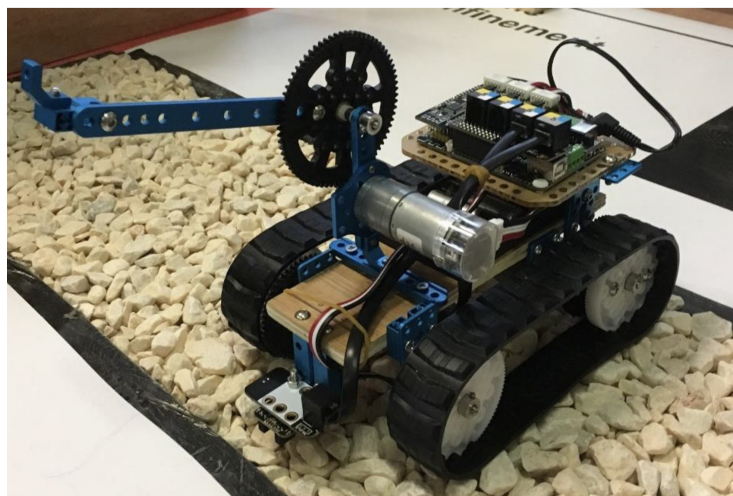

Figure 2: Deployment phase

The system, according to the sequences, could be either in automatic mode with maximum operational safety and security requirements, or in remote mode from a monitoring and control console (Figure 3), served by two separate operators depending on the operation to be performed.

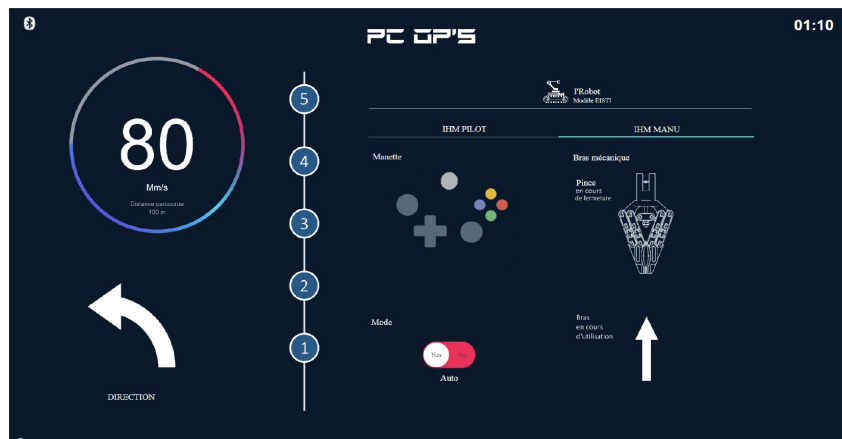

Figure 3: HMI for the handling operator

As for each edition, all the components necessary for the operation of the solution had to come from the kit provided by AFIS. This year, the exception was the bare platform of the system (Figure 4), which had to be made of material, material or product with a low ecological footprint, reused or recycled, the solution itself having to be easily recyclable at the end of its life. The satisfaction of these requirements was integrated into the evaluation of the engineering file and during the project audit. The most innovative and eco-responsible solution was awarded a special AFIS Prize.

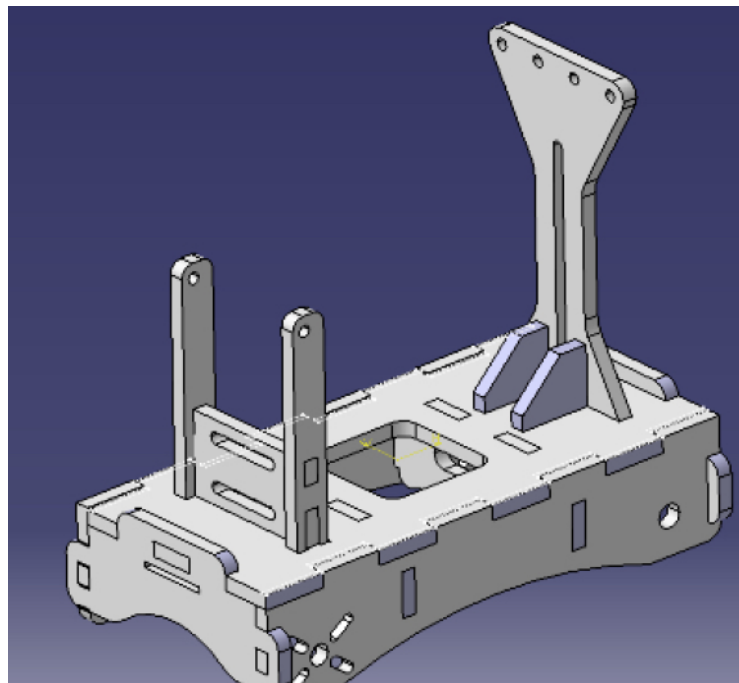

Figure 4: Platform design example

In the overall ranking, the AFIS Prizes were awarded to the 3 best teams: the EISTI of Cergy Pontoise and the INSATOMIQUE team of INSA Toulouse, were ranked 1st ex-aequo and the PANDA team of INSA Toulouse was ranked 3rd.

The NEXTER SYSTEM Award for the Best Human Factor Approach to System Engineering and Best Usability of the System was awarded to the Ecole Nationale de l'Aviation Civile de Toulouse.

The AIRBUS Maintainability Award for the best engineering and demonstration of maintenance aptitude was awarded to the Master ISC of the University of Lorraine.

The AFIS Prize for the best project audit for the innovative nature of the bare platform and the satisfaction of design and end-of-life disposal requirements was awarded to SIGMA CLERMONT.

The Alain FAISANDIER System Engineering Prize was awarded for the first time to the Master ISC of the University of Lorraine, for the quality of the development document and the implementation of systems engineering technical processes.

6. References

- [1] Tucoulou, J. C., Gouyon, D., Bonjour, E., 2011. A student challenge in systems engineering: RobAFIS 2010. *Insight Journal of INCOSE*, 14(4), 9-11.
- [2] Tucoulou, J. C., Gouyon, D., 2013. RobAFIS student competition: from systems engineering to the engineering of one system. *Insight Journal of INCOSE*, 16(4), 7-10.
- [3] Tucoulou, J. C., Gouyon, D., 2015. RobAFIS student actuality: A continuously evolving pedagogy for Systemes Engineering. *Insight Journal of INCOSE*, 18(4), 12-13.
- [4] Tucoulou, J. C., Bonjour E., Gouyon, D., 2017. The first RobAfis-RobSE international student competition in Systems Engineering. *Insight Journal of INCOSE*, 20(4), 45-46.
- [5] Fiorèse S. and Meinadier J.-P. (Eds.), 2012. To discover and understand Systems Engineering (in french). Cépaduès. ISBN: 978-2364930056.
- [6] Tucoulou, J. C., Daniel-Allegro B. & Le Put A., D.. 2014. Thinking System. AFIS. ISBN: 978.2.36493.142.8
- [7] RobAFIS dedicated web site: <http://www.robafis.fr>.
- [8] Development repository, downloadable from <http://www.robafis.fr>